

MOL-254

Automatic 2-needle Belt-Loop Attaching Machine

Shortened machine time and consistent loop feeding help increase productivity.



MOL-254 (equipped with full options)

MOL-254

MACHINE TIME 1.2 SEC./BELT-LOOP

The machine time is 1.2 seconds per belt-loop (with 28 stitches).

The new machine head specifically developed for belt-loop attaching machines runs at a maximum sewing speed of 2,500rpm and is equipped with a direct-drive system that improves start up performance and shortens sewing time. The belt-loop feeding device is now provided with a halfway standby capability for subsequent belt-loops, and its faster belt-loop supply action shortens the time required for supplying belt-loops and helps speed up the machine time to 1.2 seconds per belt-loop (with 28 stitches).



With the improved consistency in belt-loop supply action and re-try capability, the machine down time is substantially reduced.

Belt-loops are fed out by the conventional gear-roller feeding mechanism and also drawn out by the new drawing mechanism on the clamp device. Supported by these two mechanisms, the folding fork catches "curled" or "creased" belt-loops every time and supplies them to the head. In addition, the sensor of the clamp device detects the presence/absence of belt-loops. If it detects a faulty belt-loop feed, the clamp device automatically repeats the clamping action. Since the operator doesn't have to operate the set-back switch, less time is lost.



●When feeding out belt-loops



●When the finger catches belt-loops

The machine quickly and reliably disposes splices without any delays in cycle time.

The machine preliminarily detects each splice in the belt-loops and efficiently disposes them. This means that even when the machine carries out the splice-disposal procedure, the belt-loop feeding device can complete its belt-loop supply action and supply the next belt-loop well before the machine starts to sew. As a result, the operator can perform rhythmical and efficient sewing work with no delay in cycle time. By detecting changes in the material thickness, the machine's potentiometer finds splice in belt-loops and disposes them perfectly. When changing the material to be sewn, the change in the material thickness recognized by the potentiometer as a splice can be easily adjusted and programmed through the machine's teaching function.

The standard machine incorporates a 1.8-fold capacity shuttle hook. The shuttle hook improves efficiency by reducing the frequency of bobbin thread replacement.



THE MACHINE OFFERS IMPROVED FLEXIBILITY.

The newly developed machine head comes with a computer-controlled X-Y linear feeding system which enables to program the number of stitches and size of bartacking.

The number of stitches to sew a belt-loop can be switched between; 28-, 36- and 42-stitches, and the bartacking size can be easily changed through the operating panel. What's more, the user can create his/her own original sewing patterns in addition to the standard ones using JUKI's PGM-20 programming software developed for computer-controlled sewing machines.

Simple adjustment of the machine enables changeover of the cutting method between cross cutting and straight cutting.

The applicable loop width for the cross-cutting device is increased. In this model, both the cross-cutting device and the straight-cutting device can now cut loop up to 20mm width.

FINISHED BELT-LOOP STITCH SIZE

CROSS CUTTING (STANDARD)

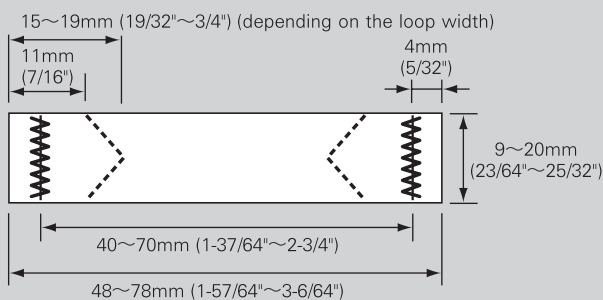

STRAIGHT CUTTING

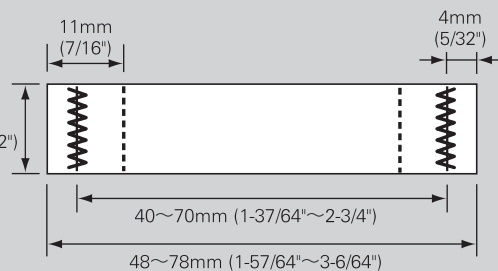

* The machine is factory-equipped with cross-cutting device at the time of delivery.

THE MACHINE OFFERS IMPROVED OPERABILITY, WORKABILITY, AND MAINTAINABILITY.

An electric sliding mechanism is installed in the front hook (near the operator).

The newly incorporated electric sliding mechanism is used to electrically shift the front hook when replacing the bobbin or conducting maintenance on nearby components in order to widen the space between the hooks and facilitate the job. In addition, when changing the needle gauge, the front hook can be finely positioned in increments of 0.01mm through the operating panel, thereby allowing the operator to easily adjust the distance between the blade points of the two shuttle hooks. Since the machine no longer requires any adjustment in the hook timing (phase), needle gauge adjustment is much simpler than ever before.



● With a minimal distance between hooks



● With a maximized distance between hooks

To enable computer-controlled belt-loop supply performance, the machine has adopted a servomotor-driven belt-loop feeding device that feeds the belt-loops to the sewing position (i.e., under the presser foot).

The belt-loop feeding position is automatically adjusted to the belt-loop width. With this capability, the belt-loop width can be easily changed without mechanical adjustment. In addition, when feeding the belt-loop under the presser foot, the widthwise position of the belt-loop can be offset through simple manipulation of the operating panel.



● The widthwise position of the belt-loop can be offset.



● The lift of the presser foot is as high as 21mm to ensure outstanding workability.

To improve workability in replacing belt-loops, the belt-loops insertion opening through which belt-loops are supplied to the feeding device is now located on the front side of the main unit.

The operator can visually check how the belt-loops are fed during sewing and prevent possible troubles in the belt-loop feed due to faulty loop-feeding paths.

The machine is equipped as standard with an adjustable stand.

The height of the working table can be easily adjusted to match the operator's height. The operator can carry out sewing works in a comfortable posture with less physical strain and fatigue.

OPTIONS



■ Belt-loop feeding device (Belt-loop slackener)

Part No.: G5730-254-0A0

The cylinder type belt-loop feeding device supports the belt-loop feeding of the main unit.

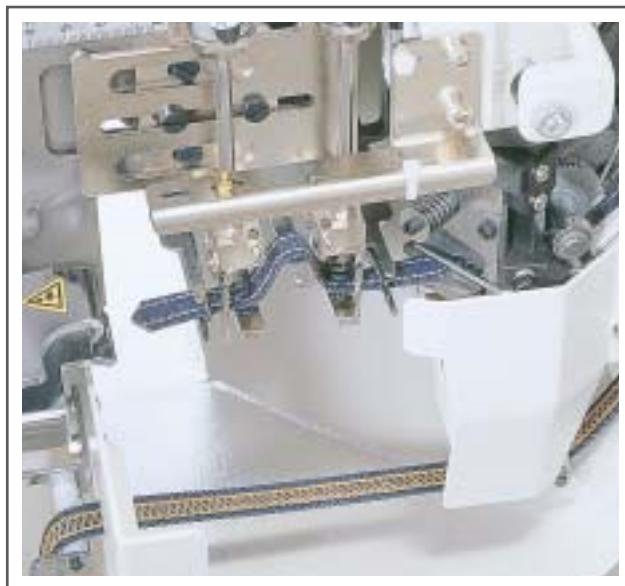

■ Belt-loop tension releasing device (fullness)

Part No.: G5700-254-0A0

The device slackens the belt-loop when attaching it on the garment body.

■ Needle cooler

Part No.: G5770-254-0A0

The device cools the frictional heat generated by the needle during sewing.

■ Needle thread breakage detector

Part No.: G5780-254-0A0

The device detects breakages in the needle thread by means of a thread take-up spring. If a needle thread breakage is detected, the device halts the sewing of the next loop.

■ Air gun assembly

Part No.: G5760-254-0A0

*A bobbin thread counter, cross-cut cloth chip suction device, and adjustable stand are installed as standard on the machine.

MAJOR SPARE PARTS

Part name	Part No.
Upper knife (loop cut knife)	G5412-254-000
Shuttle, H type	B1818-210-D0B
Shuttle race ring complete, C type	B1817-210-DAC
Needle hole guide	138-82501
Moving knife junction	138-81255
Lower plate blank	138-81008
EP-ROM for data	HL-0084230-00

SPECIFICATIONS

Model name	MOL-254
Machine head	Computer-controlled, 2-needle, lockstitch bartacking machine
Max. sewing speed	2,500sti/min*
Thread take up	Link type
Needle bar stroke	45.7mm
Thread	Spun thread, cotton thread #50~#30, B33~B46, Nm=120/3~60/3
Needle (at the time of delivery)	DP×17 (#21) #19~#21
Hook	Horizontal-axis 1.8 fold-capacity shuttle hook
Lift of the presser foot	21mm
Number of stitches	28, 36, 42 (selectable on the operating panel)
Needle gauge	40~70mm (1-37/64"~2-3/4")
Bartacking length	7~22mm (9/32"~55/64") <adjustable in increments of 0.1mm>
Bartacking width	1~3.2mm (3/64"~1/8") <adjustable in increments of 0.1mm>
Number of pieces of bartacking data that can be stored in memory	9 (99 patterns if optional EP-ROM is added)
Belt-loop width	9~20mm (23/64"~25/32")
Finished length of belt-loop	48~78mm (1-57/64"~3-5/64")
Machine time	1.2 sec./belt-loop (28 stitch)
Positioning of the front hook	Driven by motor (the distance between the hook can be established in increments of 0.01mm)
Bobbin winder	Electric type (provided as standard)
Lubrication	Centralized oil wick lubrication (machine head)
Lubricating oil	JUKI New Defrix Oil No.2 (equivalent to ISO VG32)
Power requirement and power consumption	Single-phase, 3-phase 200~240V/350VA
Compressed air and air consumption	0.5MPa (5kgf/cm ²), 32Nℓ /min
Total weight	230kg
Dimensions	1,200mm (W)×800mm (D)×1,350mm (H: in its lowest end)
Height of the top surface of the throat plate as from the floor surface	920~1,250mm (provided with the adjustable stand capability)

* "sti/min" stands for "Stitches per Minute."

WHEN YOU PLACE ORDERS

Please note when placing orders, that the model name should be written as follows:

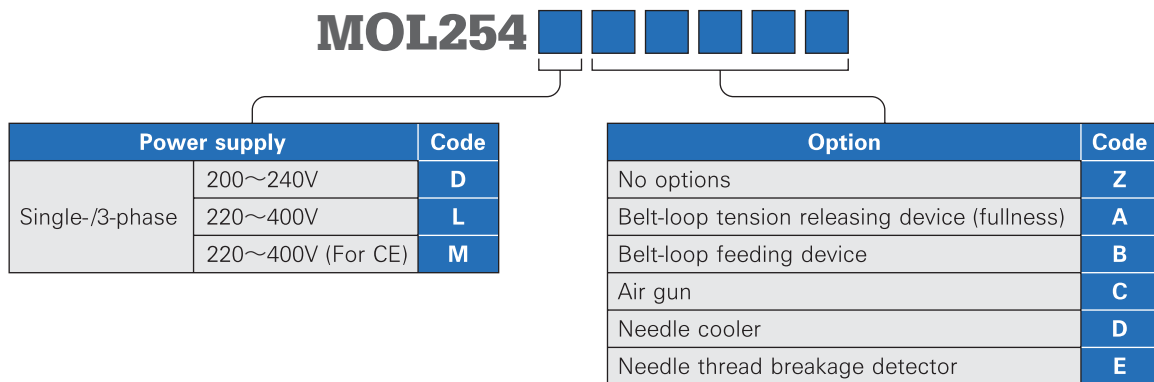

* Enter codes of required options in alphabetical order.

● To order, please contact your nearest JUKI distributor.



Registered Organization : JUKI CORPORATION Head Office
The Scope of the Registration : The activities of research, development, design, sales, distribution, and maintenance services of industrial sewing machines, household sewing machines and industrial robots, etc., including sales and maintenance services of data entry systems.

JUKI

JUKI CORPORATION
SEWING MACHINERY BUSINESS UNIT

2-11-1, TSURUMAKI, TAMA-SHI,
TOKYO 206-8551, JAPAN
PHONE : (81) 42-357-2254
FAX : (81) 42-357-2274
<http://www.juki.com>

* Specifications and appearance are subject to change without prior notice for improvement.
* Read the instruction manual before putting the machine into service to ensure safety.
* This catalogue prints with environment-friendly soy ink on recycle paper.

JUKI ITALIA S.p.A.
20020 Lainate MI - Via Bergamo, 4
Tel. 02937579.1 - Fax uffici 0293570164
Fax ricambi 0293571066
<http://www.juki.it> - E-mail: info@juki.it